

The SLBC Batch Controller combines main functions of SBSD Batch Set Unit and SLCD Indicating Controller. It can be used on its own in Batch Loader loops, or can be used with the SLCC Blending Controller in high-resolution in-line batch blending systems.

The controller functions include:

- Scaling, addition or subtraction of pulse signals, instantaneous flow display, repeater for a flow signal.
- Analog inputs and outputs, and compensation computation functions.
- Flow program set unit, batch sequences. Sequencer switches are on the front panel.
- Various totalizer functions. Totalizer parameters are easy to set, and totalizer totals may be viewed.
- Communications functions — the instrument is easy to design into a system, it can communicate with a central operator station or supervisory computer. DDC or SPC operation is possible.
- Self-diagnostic functions.

STANDARD SPECIFICATIONS

Input Signals

Process Variable Pulse Input Signal: 0 to 6 kHz, zero elevation not possible, minimum pulse width 50 μ s. Pulse input from two-wire/three-wire transmitter, or voltage transition/contact signal.

Input From Transmitter: SLBC contains distributor, voltage is switch-selectable — distributor supplies 12 V/24 V \pm 10%, current up to 50 mA. For two-wire transmitter, load resistance is switch selectable — 200 Ω , 510 Ω or 1 k Ω .

Voltage (Transition) Pulse:

Voltage LOW Level (E_L): -1 V to +8 V DC.

Voltage HIGH Level (E_H): +3 V to +24 V DC.

Amplitude of Pulse Signal ($E_H - E_L$): At least 3 V.

Input Resistance: At least 10 k Ω .

Contact Pulse: Relay/switch contact or transistor switch.

Contact ON: Source resistance up to 200 Ω .

Contact OFF: Source resistance at least 100 k Ω .

Contact Rating: At least 30 V DC, 30 mA.

Filter for Contact Pulse Input: Switch-selectable, time constant 10 ms.

Auxiliary Pulse Input Signal (Added to/Subtracted from Process Variable), and Status/Mode Select Contact Inputs: Auxiliary pulse input is 0 to 1 kHz, zero elevation not possible, minimum pulse width 350 μ s.

Status input minimum pulse width 220 ms.

Voltage (level) or contact signals.

Voltage (Level) Input:

Voltage LOW Level (E_L): -1 V to +1 V DC (status ON).

Voltage HIGH Level (E_H): +4.5 V to +25 V DC (status OFF).

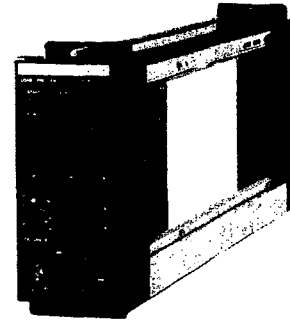

Contact Input: Relay/switch contact or transistor switch.

Contact (Status) ON: Source resistance up to 200 Ω .

Contact (Status) OFF: Source resistance at least 100 k Ω .

Contact Rating: At least 5 V DC, 20 mA.

Analog Input Signals (Process Variable or Auxiliary Flow and Compensation Signals): 1 to 5 V DC, input resistance 1 M Ω .

Analog Input Conversion Accuracy: \pm 0.2% of span.

RTD Input Signal (for Temperature Compensation):

(SLBC-301 only): JIS specification Pt 100 Ω 3-wire RTD, lead wire resistance up to 10 Ω /wire.

Temperature Compensation Accuracy: \pm 0.2% of span.

Burnout Function: Provided; scaleout time up to 60 s.

Output Signals

Pulse Output Signal (Flow Repeater or Demand Pulse Signal): Transistor contact signal, rating 30 V DC, 200 mA.

Frequency: 0 to 1 kHz; **Duty Cycle** 50% (for connecting to Yew Series BCS Instrument), or **Fixed Pulse Width** — selectable (one of 0.5, 1, 20, 33, 50 or 100 ms) — for electromechanical counter.

Status Output Signals (for flow signal input abnormal (missing/leakage), pre-batch and batch end alarms, reset and fail signals — five points): Transistor contact signals, rating 30 V DC, 200 mA.

Analog Output Signal (Flow Repeater Signal): 1 to 5 V DC, load resistance at least 2 k Ω .

Analog Control Output Signal: 4 to 20 mA DC, load resistance 0 to 750 Ω .

Analog Output Conversion Accuracy: \pm 0.3% of span.

Isolation

Contact (pulse/status) I/O signals are isolated from internal circuitry; analog signals are not. Pulse I/O signals are isolated from each other; status inputs, status outputs and analog I/O signals use separate common negative lines. Power supply is isolated from internal circuitry.

Input Processing Functions

Process variable and auxiliary flow inputs may be either voltage or pulse signals, compensation input may be either a voltage or RTD signal.

Auxiliary Flow Signal Processing:

Auxiliary flow signal can be added to or subtracted from process variable signal. Range of analog output (to PI algorithm, display and repeater) is adjustable.

Voltage Flow Signal Processing: Span setting (4-digit fixed point number) corresponding to input signal range of 1 to 5 V DC; low-input cutoff (for inputs under 1% of span) and square root function selectable.

Input Filters (for Process Variable Pulse Input and Auxiliary Pulse Input): First order lag filters, time constant adjustable 0 to 9999 s.

Totalizer Scale Factors: Scaler for pulse signal input (constant K number of pulses for every flow unit totalized). Totalizer scale factor for analog signal input. K (K_1 , K_2) are 5-digit fixed point numbers, of maximum value 32767.

Compensation Computations

Can compensate the process variable and auxiliary flow signals for liquid density changes with temperature. Other types of compensation are also possible (see below).

SLBC has the following 4 ASTM compensation.

- Old ASTM No. D1250 (edit in 1952)
 - New ASTM No. D1250 (edit in 1980)
- for crude oils, fuels & solvents and lubricating oils.

Temperature Compensation:

Temperature unit is selectable (°C or °F).

Input Signal: Platinum RTD (Pt 100 Ω) or 1 to 5 V DC.

Temperature Range: For platinum RTD (Pt 100 Ω); -50 to +250°C.

For a 1 to 5 V DC signal: Arbitrary.

Computation Format: ASTM equation or general quadratic equation.

ASTM Equation: $V_0 = V[(1 + \alpha)f(\rho, t)]$

General Quadratic Equation:

$$V_0 = V\{(1 + \alpha)[1 + \beta(t - t_0) \times 10^{-2} + \gamma(t - t_0)^2 \times 10^{-6}]\}$$

V_0 : Volumetric flow at reference temperature t_0 .

V : Volumetric flow (process variable flow signal) at temperature t .

t_0 : Reference temperature (°C), $t_0 = 15^\circ\text{C}$ for ASTM.

t : Flow sensor temperature (°C).

α : Flow transmitter compensation coefficient, (-99.99 to +99.99).

β : First order compensation coefficient, (-99.99 to +99.99).

γ : Second order compensation coefficient, (-99.99 to +99.99).

ρ : Specific gravity, (0.5000 to 1.2000)

Note: For density (specific gravity) compensation, coefficients α and ρ are used to convert volumetric flow to ASTM standard conditions $t_0 = 15^\circ\text{C}$.

General Compensation Computations:

Computation Format: $V_0 = V[(C_{\max} - C_{\min})C + C_{\min}]$, C ranges from 0 to 1 - its value corresponds to the compensation input signal: a voltage in the range 1 to 5 V DC. C_{\max} and C_{\min} are maximum and minimum compensation coefficients respectively, and may be set independently in the range 0 to 9999.

GS 1B4E3-E

Flow Signal Repeater/Demand Pulse Output Function

Outputs pulse and analog signals corresponding to the flow signal process variable input (the instrument can also add or subtract an auxiliary flow signal input - in this case, the span of analog output (to PI algorithm, display and repeater) is adjustable). Can output a demand pulse signal which corresponds to current set point in flow program.

Pulse Output: Output pulse rate may be scaled by a factor K' . K' (K_3 , K_4) are 5-digit fixed point numbers, of maximum value 32767.

Pulse Output ON Time: Selectable - one of 0.5, 1, 20, 33, 50 or 100 ms - or duty cycle of 50% (for Yew-Series BCS Instruments; up to ten may be connected in parallel with output).

Analog Output (Flow Signal Repeater Signal): 1 to 5 V DC.

Totalizer Functions

Five totalizers are built in - three 6-digit batch totalizers and two 8-digit (cumulative) totalizers:

- Batch flow totalizer (process variable only).
- Batch flow totalizer (process variable, with compensation computation).
- Batch flow totalizer (process variable, with auxiliary flow signal added to or subtracted from it, and compensation computation).
- Cumulative flow totalizer (process variable, with auxiliary flow signal added to or subtracted from it).
- Cumulative flow totalizer (process variable, with auxiliary flow signal added to or subtracted from it, and compensation computation).

Batch totalizer is reset after end of each batch by reset input signal or front panel reset pushbutton. Cumulative flow totalizer may be reset manually by entering other data for totalizer value.

Data Display and Data Setting Functions

Data Display:

Upper display is batch loader setting, 6 digits.

Lower display is selectable data, 6 digits.

Selectable data (displayed in lower display) may be major data item or auxiliary data item:

Major Data Item: Displayed data type is indicated by lamp next to data item label on front panel. Value of batch flow totalizer (for process variable with auxiliary flow signal added to or subtracted from it, and compensation computation), batch setting, instantaneous flow high limit and instantaneous flow may be displayed.

Auxiliary Data Item: Displayed data type is indicated by code displayed in upper display. Auxiliary data includes the other four totalizer values, pre-batch alarm setting, program set parameters and control parameters. A table of data that may be displayed is on the instrument side panel.

Instantaneous Flow Display: 5-segment bar graph.

Data Setting:

Displayed Data Selection: Selected by push buttons.

One switch (on side panel) changes from major data display to auxiliary data display.

Data Setting: Uses push button switches. Data setting may be inhibited (disabled) by an inhibit/enable switch on the side panel.

SLBC Modes

The SLBC Batch Controller offers the following modes:

- Constant-flow manual unit, with ramp-up/ramp-down functions.
- Batch loader in a batch-blending control system (combination of batch set station and PI controller). (See batch sequence in table and flow setpoint program in figure). Program is started by start status input or start pushbutton on front panel. Can be used as slave controller with master pacing input – input status changes (ON/OFF or OFF/ON) cause the output to ramp between high and low flow limits.
- Batch master station (like the SBSB) – batch setpoint program, output directly to slave controllers. (May be switched between master and batch loader modes by contact input).
- SPC or DDC modes are also possible.

Emergency Stop/Restart (see figure): Provided for batch loader modes (see above) using stop/start pushbuttons on front panel or external stop/start status inputs. Ramp change in output between high and low flow limits, step change in output between low flow limit and zero.

Batch Functions

Batch Sequence:

Batch status	Status input/output	Lamp lit LOAD, PRE, END	Status output		
			Pre-batch	Batch	Reset
Start	Pushbutton or status input	LOAD lit	OFF to ON*	OFF to ON	—
Pre-batch	Batch-end pre-alarm output	PRE lit	ON to OFF	ON	—
Batch end	Batch end output	END lit LOAD off	OFF	ON to OFF	—
Reset	Pushbutton or status input	PRE, END off. LOAD*** flashing.	OFF	OFF	ON (momentary)
Stop	Pushbutton or status input	LOAD** PRE, END flashing.	OFF	ON to OFF***	—

- *: Contact closes when the initial flow limit (see diagram below) is reached.
- ** : LOAD lamp flashes when STOP status input is turned OFF (STOP condition) or RESET status input is turned ON.
- ***: Contact opens after program ramps flow set point down to zero.

Batch Computation Period: 0.04 seconds.

Setpoint Program:

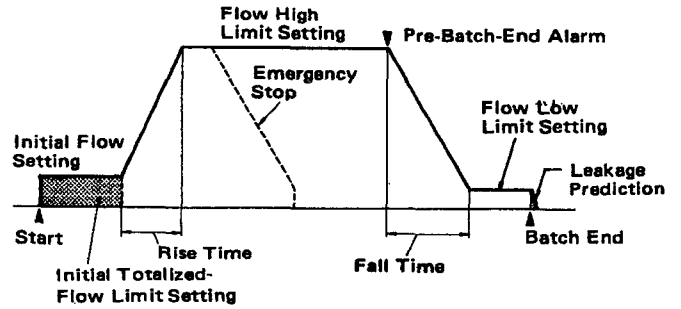

Control Functions

The SLBC contains a PI controller.

Control Modes: A (Auto) and M (Manual). (These correspond to SPC and DDC respectively in computer (remote setting) mode).

Auto Mode: PI control.

Proportional band 6.3 to 999.9%.

Integration time constant 1 to 9999 sec.

Manual Mode: Two speed operation.

Slow – 40 sec./full span change.

Fast – 4 sec./full span change.

Control Mode Transfer: Bumpless and balanceless A/M transfer.

Manipulated Variable Output Indication: Horizontal scale 39 mm long, one pointer, with two memory pointers and valve open/close direction marks.

Indicator Accuracy: ±2.5% of span.

Control Period: 0.2 sec.

Alarm Functions

Detects loss of flow process variable input signal between the time flow should have reached high limit setting and pre-batch-end. ALM lamp lights, alarm output contact opens.

Leakage Detection: Detects leakage flow between batch end and reset. ALM lamp lights, alarm output contact opens.

Communication Functions

The SLBC can communicate (via LCS card in field control station/unit) with a central YEWPACK/CENTUM CRT-display operator station and supervisory computer. Maximum length of (SCCD) cable to LCS card is 100 m (328 ft).

Data Transmitted: Instantaneous flow, batch flow totalizer value (process variable, with auxiliary flow signal added to or subtracted from it, and compensation computation), batch loader setting, initial flow setting, initial totalized flow limit setting, high flow limit setting, manipulated variable output, control mode, batch status, alarm status, compensation coefficients etc.

Data with Remote Setting: Batch loader setting, batch flow totalizer value (process variable, with auxiliary flow signal added to or subtracted from it, and compensation computation), initial flow setting, initial totalized-flow limit setting, high flow limit setting, manipulated variable output (in manual or DDC modes), control mode, batch sequence status, compensation coefficients etc. Remote setting (from YEWPACK/CENTUM operator station or supervisory computer) can be disabled.

Computer/Auto/Manual (C/A/M) Mode Switches on SLBC Front Panel: Lamps in these switches indicate instrument mode. The mode (Computer/Auto/Manual) can be checked and changed by a supervisory computer or from a remote operator station. During SPC/DDC operation from a supervisory computer, only the "C" (Computer) lamp is lit. During local operation, or remote operation from the YEWPACK UOPS operator station, the "A" or "M" lamps are lit.

Power Fail/Restart Functions

Totalizer Value: Not changed by power failure.

Batch and Control Functions:

For a power failure of up to approximately 2 seconds – instrument status may remain normal (as if there were no break), or revert to that after an emergency shut down (either action selectable).

For a power failure of more than 2 seconds – instrument status reverts to that after an emergency shut down.

Data Memory Backup During Power Failure: By internal battery. All contact outputs are OFF during a power failure.

Life of Internal Battery (temperature up to 45°C):

At least five years (normal operation).

At least one year (backup operation).

Self-Diagnostic Functions

The cause of the alarm is indicated as a numeric code.

Computation and Control Circuit Abnormal Alarm:

FAIL lamp lights and fail contact output opens. (Manual operation is possible).

Input Signal Abnormal, Manipulated Output Open, Power Failure, Pulse Repeater Overflow, Data Setting Overrange: ALM lamp lights.

Memory Backup Battery Low: ALM lamp flashes.

Communications Abnormal: Applies to computer (remote) mode. "C" lamp flashes (and SLBC reverts to backup mode → Auto or Manual selectable) while abnormal.

Simulation Functions

In simulation mode, flow signal is internally generated, and batch and totalizer functions may be checked.

Normal Operating Conditions

Ambient Temperature: 0 to 50°C (32 to 122°F).

Ambient Humidity: 5 to 90% Relative Humidity (non-condensing).

Power Supply: Two versions, for "100 V" (standard) or "220 V" (option /A2ER). Both versions may use AC or DC, without change to the instrument:

Version	"100 V"	"220 V"
DC (polarity reversible)	20 to 130V	120 to 340V
AC (47 to 63 Hz)	80 to 138V	138 to 264V

Maximum Power Consumption:

	24 V DC	100 V AC	220 V AC
SLBC-201	540 mA	22.6 VA	28.5 VA
SLBC-301	560 mA	23.2 VA	29.4 VA

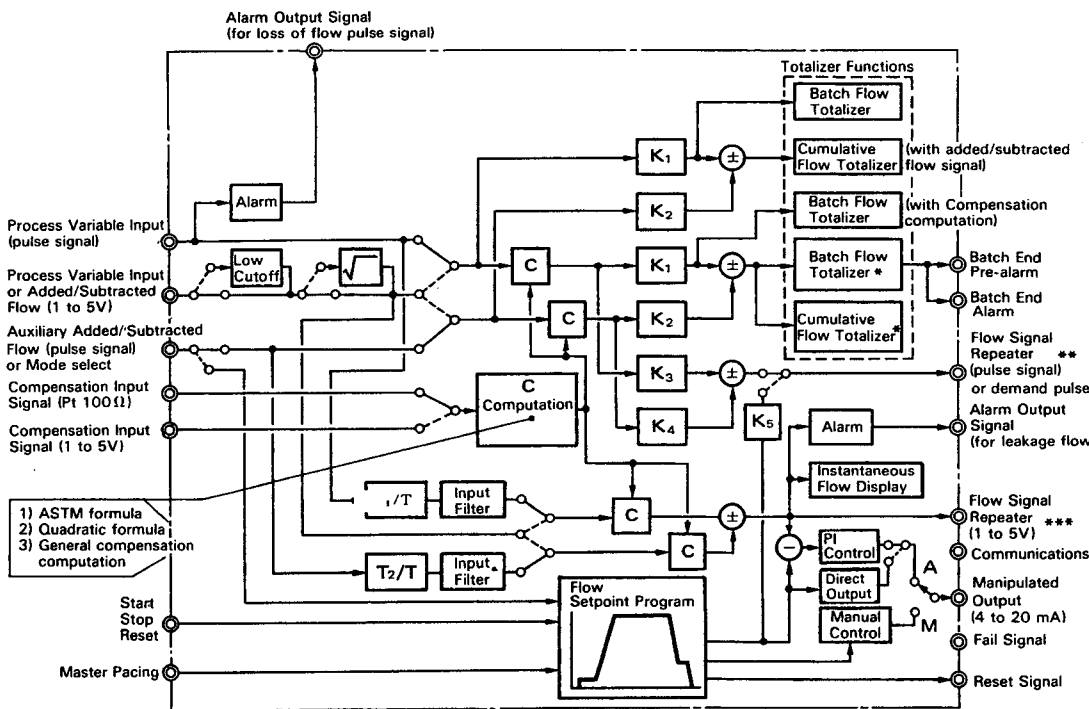

- * With added/subtracted flow signal, and compensation computation.
- ** e.g. demand pulse output
- *** The span of 1 to 5 V analog output (and the input to PI algorithm, display and repeater) are also adjustable when auxiliary (added/subtracted) flow input is used.

	Pulse input	1 to 5V input
K ₁	$\frac{1}{K \text{ factor for flow process variable}}$	$\frac{\text{Flow process variable span}}{\text{day or h or min}} \times \text{Totalizer scale factor}$
K ₂	$\frac{1}{K \text{ factor for added/subtracted flow}}$	$\frac{\text{Added/subtracted flow span}}{\text{day or h or min}} \times \text{Totalizer scale factor}$
K ₃	$\frac{\text{Repeater pulse K factor}}{\text{Flow process variable K factor}}$	$\frac{\text{Flow process variable span}}{\text{day or h or min}} \times \text{Totalizer scale factor} \times \text{Repeater pulse K factor}$
K ₄	$\frac{\text{Repeater pulse K factor}}{K \text{ factor for added/subtracted flow}}$	$\frac{\text{Added/subtracted flow span}}{\text{day or h or min}} \times \text{Totalizer scale factor} \times \text{Repeater pulse K factor}$
T ₁	$\frac{\text{day or h or min}}{\text{Flow process variable span}} \times \text{Totalizer scale factor} \times K \text{ factor for flow process variable}$	
T ₂	$\frac{\text{day or h or min}}{\text{Added/subtracted flow span}} \times \text{Totalizer scale factor} \times K \text{ factor for added/subtracted flow}$	
T	Period of input pulse	
C	Compensation computation	
K ₅	$\frac{\text{Repeater span} \times \text{Demand pulse scale factor} \times \text{Repeater pulse K factor}}{\text{day or h or min}}$	

Insulation Resistance:

Between I/O terminals and ground: 100 M Ω /500 V DC.

Between power and ground: 100 M Ω /500 V DC.

Withstanding Voltage:

Between I/O terminals and ground: 500 V AC for one minute.

Between power and ground:

1000 V AC for 1 minute (100 V version).

1500 V AC for 1 minute (220 V version).

Wiring:

Signal Wiring to/from the Field: ISO M4 size (4 mm) screws on terminal block.

Power and Ground Wiring:

100 V version: JIS C 8303 two-pin plug with earthing contact. (IEC A5-15, UL498).

220 V version: CEE 7 VII (CENELEC standard) plug.

Power Cable Length: 30 cm (11.8 in).

Mounting:

Flush panel mounting. Instruments are in housings, and may be mounted individually or side-by-side.

Rear of instrument may be up to 75° below front (indicator zero may need readjustment).

Nameplate:

Size: 8 × 65.3 mm, cream semi-gloss finish.

Lettering: In black, one or two rows each up to 14 alphanumeric characters long.

Front Panel Finish: Dark green (Munsell 2.5GY 3/1).

Bezel: Aluminium diecast, black baked-enamel finish.

Housing: Open front, with connector for SPBD Portable Manual Station.

Housing Dimensions: 182.5 (H) × 87 (W) × 480 (D: depth behind panel) (mm) (7.2 × 3.4 × 18.9 in).

Weight:

Instrument body: 3.2 kg (7.0 lb) (excluding housing).

Housing: 2 kg (4.4 lb) (excluding mounting kit).

OPTIONS

/DL: With data set as per data sheet, and corresponding data label attached.

/A2ER: For "220 V version" power supply.

/MTS: Supplied with kit for individual mounting.

For mounting in groups, see GS 1B4F1-E.

/SCF-G□M: Mounting kit bezel color change from standard color (black). Choose color from set of optional colors (see GS 22D1F1-E). Specify color code in space □.

/NHS: No housing, plug-in instrument module only. See GS 1B4F1-E to order housing separately.

/NPE: Letters engraved on front panel nameplate.

ACCESSORIES

1A fuse, quantity one.

Engineering units labels, one set.

MODEL AND SUFFIX CODES

Model	Suffix codes	Style	Option codes	Description
SLBC	Batch controller with communication and compensation functions
Compensation Input	-2 -3	1 to 5V DC Pt 100 Ω RTD
Option	01	Always 01
Style Code	*E.....	Style E
Additional spec.			/DL	With data sheet
Common Options			/A2ER /MTS /SCF-G□M /NHS /NPE	220V power supply* With mounting kit Bezel color change Without housing Nameplate engraving

* Specify /A2/NHS to order without housing.

TERMINAL CONNECTIONS

Terminal Designation	Description	Terminal Designation	Description
1		17	+ Communication *2
2		18	-
3			
4		19	+ Auxiliary pulse-type flow signal input or mode select contact input
5		20	- Fail output (- terminal)
6		21	-
7		A	+ Manipulated output, 4 to 20mA DC
8		B	-
9	+ Process variable input, or auxiliary flow input, 1 to 5V DC	C	+ Flow signal repeater (pulse output) or demand pulse output
10	- Master pacing input	D	-
11	+ Start input	F	+ Reset output (+ terminal)
12	+ Reset input	H	
13	+ Stop input	J	+ Flow signal repeater (1 to 5V output)
14	- Common	K	-
15	+ Pre-batch output	L	+ Alarm output
16	+ Batch end output	M	-
	- Common (and reset output) terminal	N	+ Fail output (+ terminal)

*1:

Terminal Designation	Contact, or Voltage-Transition Pulse	2-wire Transmitter *5	3-wire Transmitter *5
1			Sig
2			-
3			+ Transmitter

*2: Use shielded twisted-pair cable (SCCD see GS 34B6T1-01E).

*3: For Model SLBC-301 only.

*4: For Model SLBC-201 only.

*5: 12V/24V distributor for transmitter built into SLBC.

ORDERING INSTRUCTIONS

When ordering, specify the following:

1. Model, suffix and option codes.
2. Nameplate marking, if required (option /NPE).
3. Mounting kit (option /MTS) if the instrument is to be mounted individually.
4. Fill out the appropriate data sheet if data labels are required.

RELATED EQUIPMENT

Related Instruments

SBSD Batch Set Station	GS 1B4E1-E
SLCC Blending Controller	GS 1B4E2-E
STLD Totalizer	GS 1B4E4-E
SPCM Pulse Computing Unit	GS 1B4L4-E
UFCH Field Control Unit	GS 34B6G1-01E
SCCD Communications Cable	GS 34B6T1-01E

Related Spare Parts

Memory Backup Battery	Part No. E9711DH
-----------------------	------------------